

American Champion Aircraft Corp.
Rochester, WI 53167

Service Letter: 418 (page 1 of 5) Revision A

Date: January 19, 2001

Title: Electrical System Update

Applicable Models: All Model 7FC, 7GC, 7HC, 7GCA, 7JC, 7GCB, 7KC, 7GCBA, 7KCAB, and 7ACA
All other early model 7's (7AC, 7BCM, 7CCM, 7DC, 7EC, and S7EC) with electrical systems
All Model 7ECA, serial numbers 1 through 1381-2000
All Model 7GCAA, serial numbers 1 through 438-2000
All Model 7GCBC, serial numbers 1 through 1288-2000
All Model 8KCAB, serial numbers 1-70 through 859-2000
All Model 8GCBC, serial numbers 1-74 through 412-2000

Description: There have been reports of electrical system related problems including grounded wires causing fires and grounded wires melting through the insulation of adjacent wires, grounding them as well. Several causes can lead to these conditions including aged wires and insulation, improper installation, and insufficient inspection. To help prevent further instances of failures, the electrical system should be modified as described in this service letter.

Note: It is important to understand that there is a wide variety of installations spread across many aircraft models and encompassing many years of production. Not all specific instructions can apply to every airplane. It is suggested that the principals of the changes be applied as closely as possible.

Compliance: American Champion Aircraft recommends that the system be inspected within the next 30 hours of flight time. It is recommended that the modifications described herein take place during the next annual inspection. Required parts can be found in Service Kit 418A (for firewall mounted batteries) or Service Kit 418B (for aft mounted batteries).

The inspection procedures described herein are not intended to be a substitute for a properly performed 100 hour / annual inspection. Refer to Advisory Circular (AC) 43.13: Acceptable Methods, Techniques, and Practices; Aircraft Inspection and Repair.

Inspection: Inspect the electrical system for general condition (wear, connections, resistance, etc.). If an electromechanical voltage regulator and over-voltage relay are installed, check them for proper operation.

Concept: The primary electrical system on most rear mounted battery models looks similar to the schematic in figure 1. The diagram has been simplified to show only the affected areas. Upon inspection, it can be seen that there is no circuit protection for the voltage regulator circuit before the voltage regulator. This wire is in a bundle with other critical wires and is a source of concern. Also, the circuit from the battery to the bus bar is not protected. This was due to the 'sharing' of a line to the starter. To accommodate circuit protection for these two circuits, the electrical system must be modified to look similar to figure 2.

American Champion Aircraft Corp.
Rochester, WI 53167

Service Letter: 418 (page 2 of 5) Revision A

Date: January 19, 2001

Title: Electrical System Update

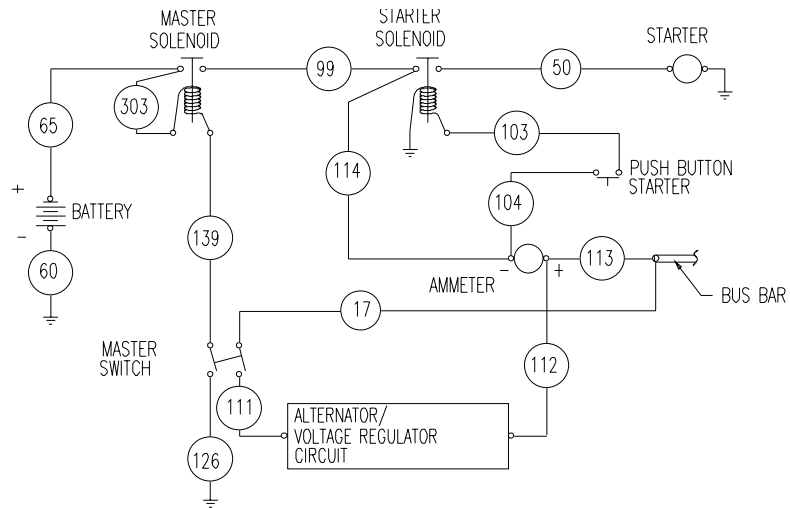

Figure 1 Schematic of Primary Electrical System (Aft Mounted Battery) Before Modification

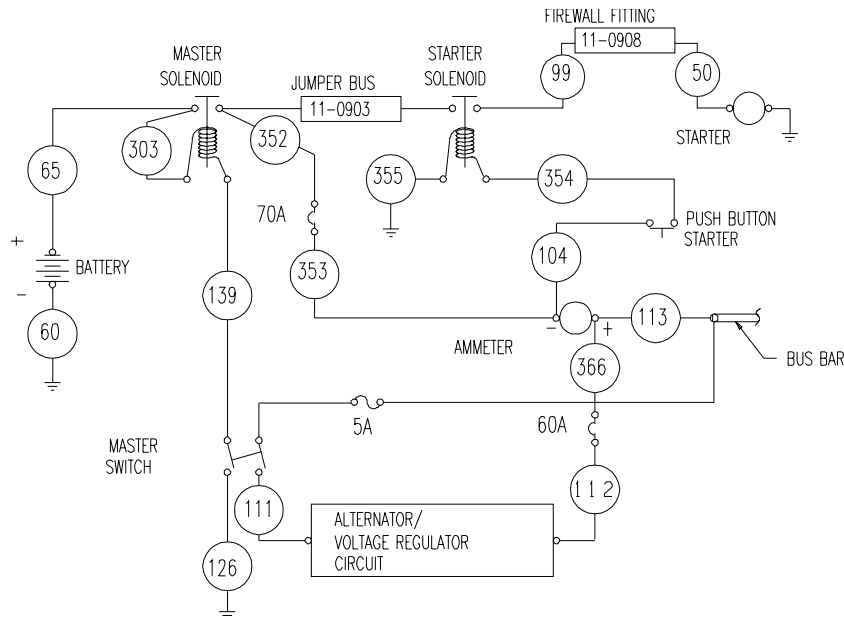

Figure 2 Schematic of Primary Electrical System (Aft Mounted Battery) After Modification

Note: Figure 1 is typical to rear mounted batteries. The wire numbers and exact wiring may vary slightly between aircraft. This letter will refer to the numbers given in Figures 1 and 2.

Conversion: The following paragraphs describe the changes needed to comply with this service letter. Before working on the electrical system, be sure all systems are shut off and the battery is not connected. Take all possible safety precautions before working on the aircraft. All splicing, wire routing, and terminal installation should be done in accordance to Advisory Circular (AC) 43.13-1B.

American Champion Aircraft Corp.
Rochester, WI 53167

Service Letter: 418 (page 3 of 5) Revision A

Date: January 19, 2001

Title: Electrical System Update

Conversion: The first item that needs to be modified is the voltage regulator circuit. Wire number 17 must be replaced with an inline 5-amp fuse. This is a very short wire inside the electrical panel that runs from the bus bar to the alternator half of the master switch. Note that the master switch is a single throw double pole switch and connecting to the wrong pole will ground the bus bar when the switch is thrown. This fuse can be butt spliced in place or new terminals can be installed depending on application.

- The following procedures assume the battery is mounted on the firewall.

A properly installed firewall mounted battery requires the installation of circuit protection from the battery and the alternator. Mount the 70-amp battery circuit breaker inside the firewall using an Adel clamp and 11-0902 bracket. On the output side of the master solenoid, disconnect wire #114 and, mount wire #367 to the input (line) side of 70-amp circuit breaker. The wire #114 should then be attached to the output (load) side of the circuit breaker. Figure 3 depicts a typical installation.

Attach the 60-amp alternator circuit breaker to the diagonal fuselage tube with an Adel clamp and 11-0902 bracket. Disconnect the #112 wire from the ammeter and replace it with wire #366 attached to the input (line) side of the 60-amp circuit breaker. Attach alternator wire #112 to the output (load) side of the 60-amp circuit breaker. Figure 3 depicts a typical installation.

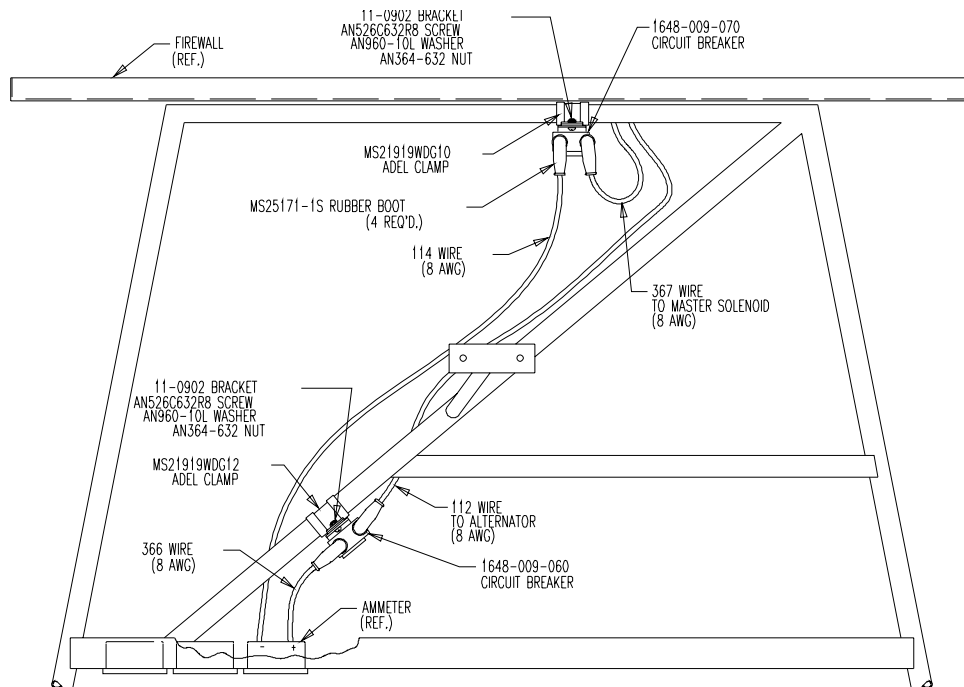

Figure 3 Typical installation for a Firewall Mounted Battery

American Champion Aircraft Corp.
Rochester, WI 53167

Service Letter: 418 (page 4 of 5) Revision A

Date: January 19, 2001

Title: Electrical System Update

- The following procedures assume the battery is mounted aft of the baggage compartment.

Conversion: The best way to separate the starter circuit from the ammeter / bus bar circuit is to relocate the starter solenoid close to the master solenoid. First, disconnect the starter solenoid from all of its connections including wires 50, 99, 103, and 114. Wires 103 and 114 can be removed from the airplane, as they will be too short for further use.
(Continued)

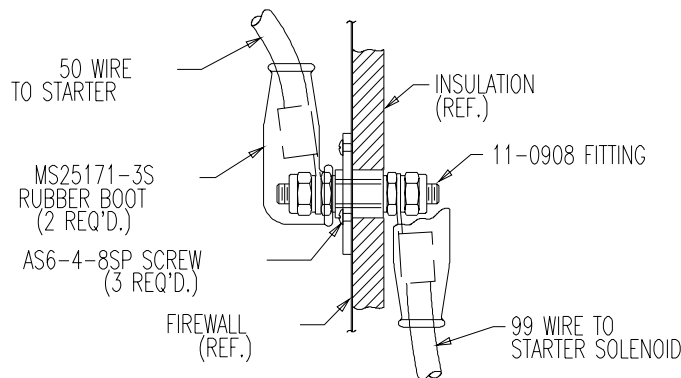

Figure 4 Assembly of Firewall Fitting

Remove the firewall fitting for wire #99 and push inside the airplane. Install fitting 11-0908 in the firewall in place of the former fitting. Mount wire #50 to the engine side of the fitting and wire #99 to the insulation side of the fitting. Use a rubber boot over each connection. The Assembly is depicted in figure 4. The starter solenoid should then be mounted to the battery board in close proximity to the master solenoid as depicted in Figure 5. This may require that the master solenoid be shifted as well. The wire #99 should be removed from the master solenoid and mounted to the starter solenoid. The 11-0903 jumper bus should then connect the two solenoids. The starter solenoid needs to be grounded if it is mounted on a wood battery board. Use wire #355 to connect to an appropriate ground. Route wire #354 up to the starter button in place of the former wire #103. Figure 5 depicts a typical installation.

Important: All connections should use an appropriate rubber boot to protect the connection

Power to the bus bar from the battery must be restored by replacing wire #114. On the output side of the master solenoid, mount the short wire #352 to a 70-amp circuit breaker. Mount the breaker to the battery board using an appropriate bracket. This is also depicted in figure 5. Route the longer wire #353 to the ammeter in place of wire #114. The #353 and #354 wires should be bundled with wire # 99 to keep them away from fuel lines and control systems.

Lastly, attach the 60-amp alternator circuit breaker to the diagonal fuselage tube with an Adel clamp and 11-0902 bracket.

American Champion Aircraft Corp.
Rochester, WI 53167

Service Letter: 418 (page 5 of 5) Revision A

Date: January 19, 2001

Title: Electrical System Update

Disconnect wire #112 from the ammeter and replace it with wire #366 attached to the input (line) side of the 60-amp circuit breaker. Attach alternator wire #112 to the output (load) side of the 60-amp circuit breaker. Figures 5 and 6 depict a typical installation.

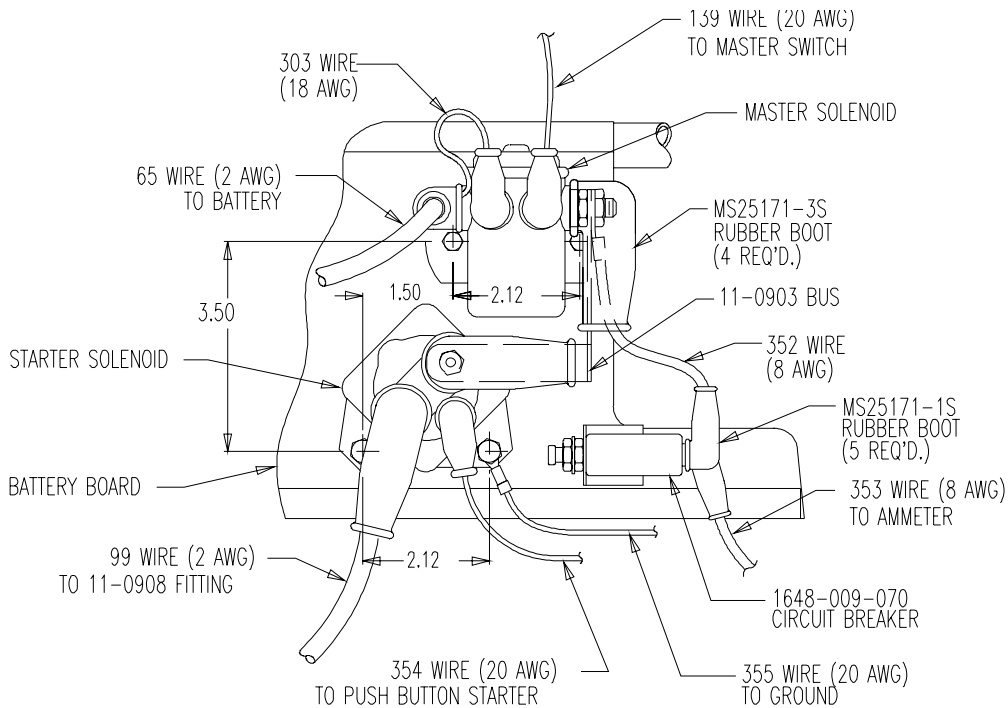

Figure 5 Typical Battery Board Installation

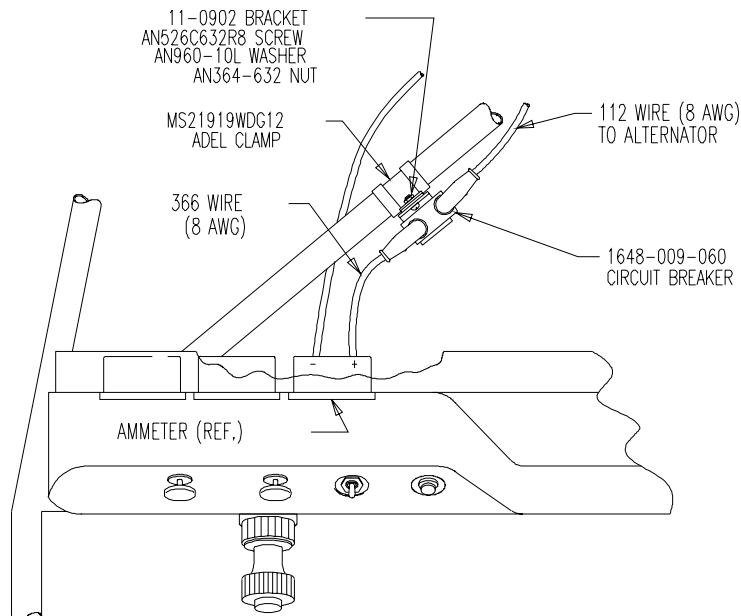

Figure 6 Under Dash Installation for Aft Mounted Battery